

GRATING FIELD FABRICATION GUIDE

FIBERGLASS GRATING & STAIR TREADS

Typical Fabrication & Installation of Fiberglass Grating & Stair Treads

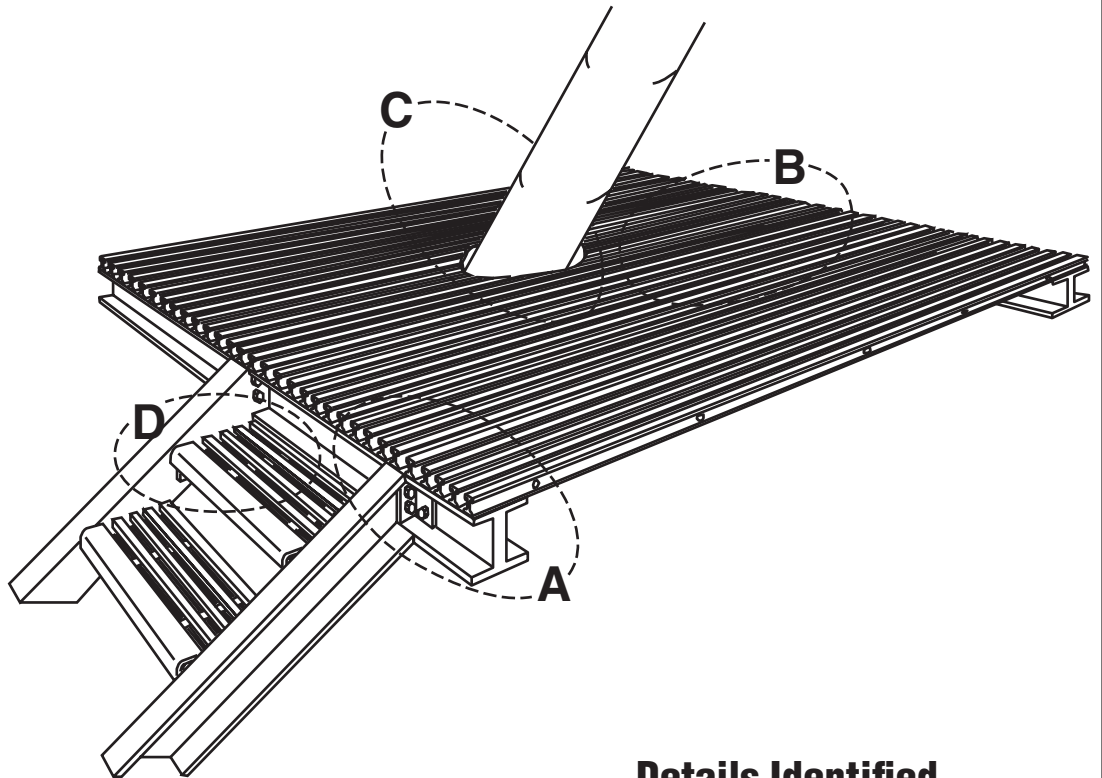

**Details Identified
on Pages 2 & 3**

STEPS OF FABRICATION

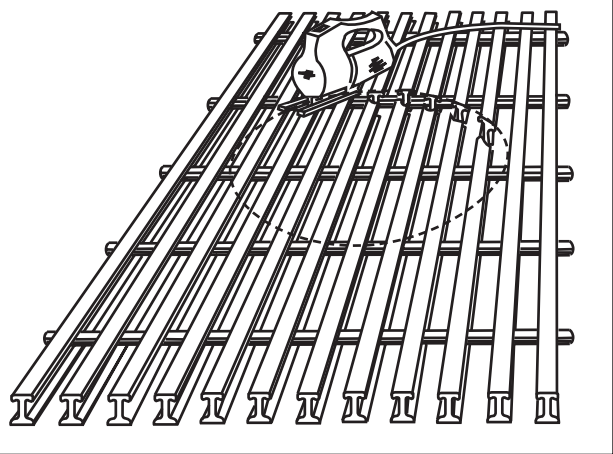
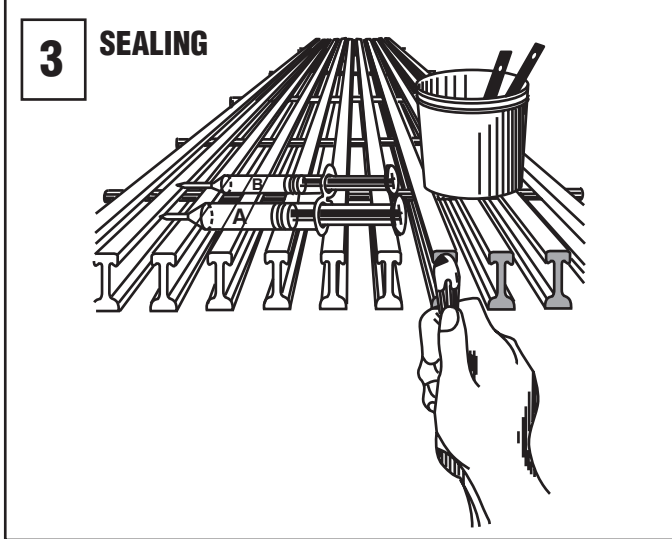
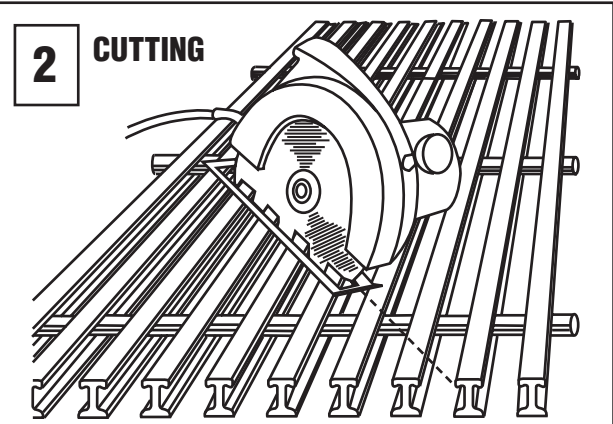
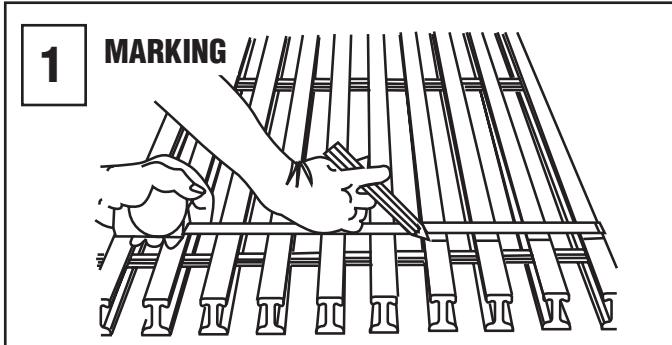

DURADEK[®] / DURAGRID[®] INSTALLATION

A PANEL HOLD DOWNS

Weldable 316L stainless steel saddle clips are available for all grating series, except the T-1800 and T-3500 series.

Weldable 316L stainless steel insert clips are available for all grating series, except the T-1800 and T-3500 series.

Weldable 316L stainless steel insert clips are available for series T-1800 and T-3500 only.

**Bolts are prices separately from the saddle clips.*

**Bolts are prices separately from the hold down.*

**Bolts are prices separately from the hold down.*

NOTE: Recommend 2 hold downs at each support with a minimum of 4 per panel.

B PANEL CONNECTORS

316L stainless steel saddle clips are available as panel connectors for I-bar grating and 2" T-bar grating.

Insert clip hold downs are available for I-bar grating and 2" T-bar grating.

Insert hold downs are available for 1" T-bar grating.

NOTE: Panel Connectors are generally only used at midspan to assist in transferring load from section to section.

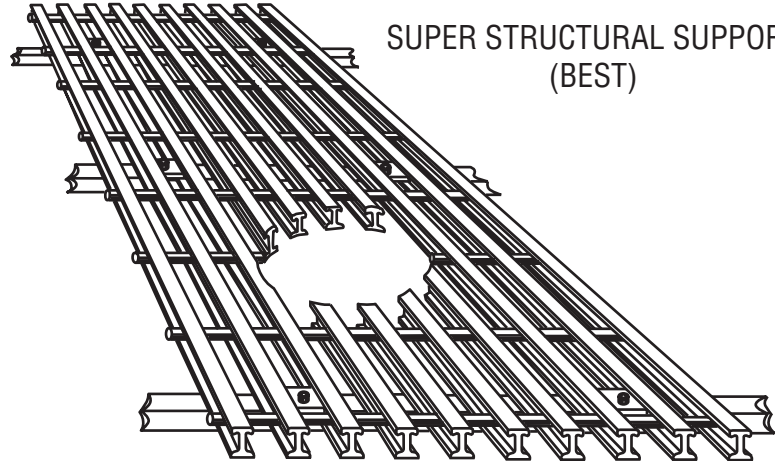
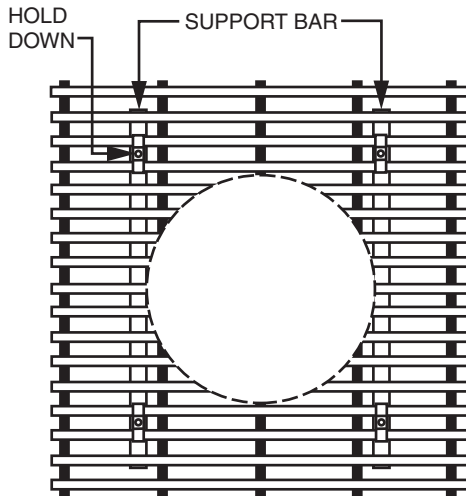
C**SUPPORTING AROUND CUTOUT AREAS****SUPER STRUCTURAL SUPPORT
(BEST)**

- It may be necessary to add additional super structural supports around cleanout area to support grating bearing bar ends.
- If it is not possible to add super structural supports around cutout area, the alternate method shown at the left is recommended.
- Position hold downs on two uncut bearing bars beyond cutout area. (Distance between hold downs determines length of support bar needed.)
- Secure hold downs to support bar.

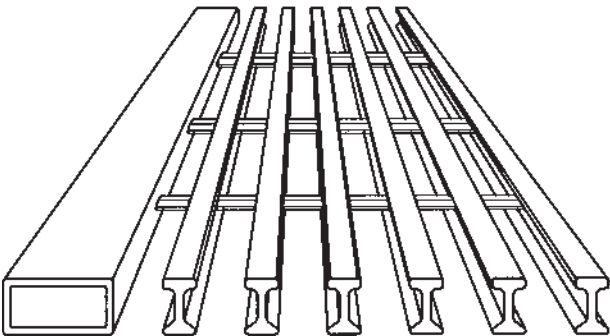
D**STAIR TREADS**

2" rectangular shaped nosing is used for all grating with depths of 1" and 1-1/2".

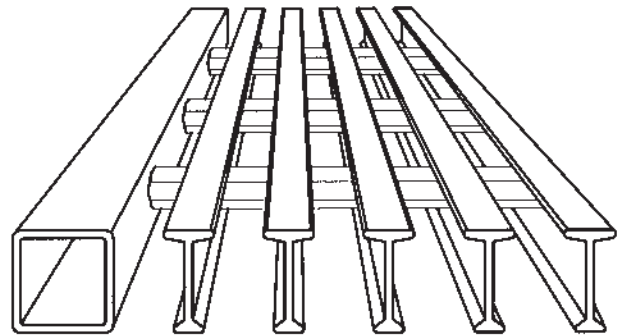

"Box" shaped nosing is used for all grating with 2" depths.

HOLD DOWNS ARE NOT PROVIDED WITH STAIR TREADS. FOUR S.S. SADDLE CLIP HOLD DOWNS RECOMMENDED PER TREAD.

SUPPORT ANGLES NOT PROVIDED. SUPPORT ANGLES AND OTHER FIBERGLASS STRUCTURES AVAILABLE FROM CHATFIELD DIVISION.

DURAGRATE® INSTALLATION

DURAGRATE® molded fiberglass panels are fabricated like DURADEK®/DURAGRID®. Use hold down clips to prevent panel drift. Hex bolt, nut and washer are available.

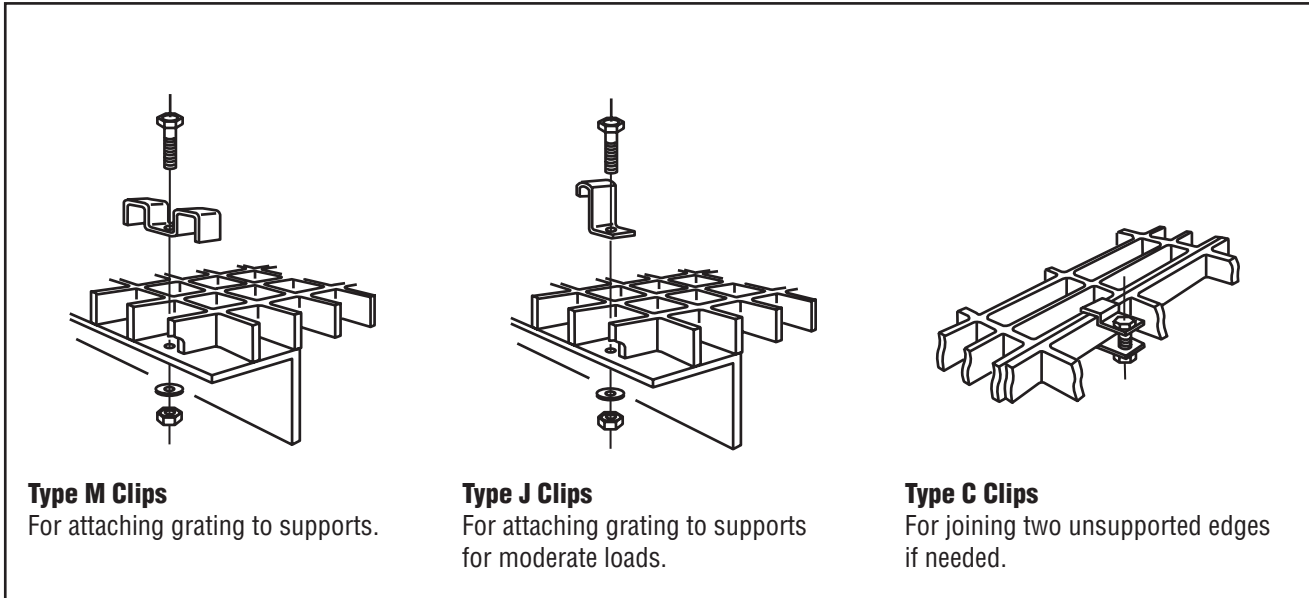

Grating Legs

Fixed and adjustable legs for molded grating are available to provide sturdy support for elevated flooring. Contact the Chatfield Division for your exact requirements.

TOOLS	• CIRCULAR SAW	• 3/16" ALLEN WRENCH	• SEALING KIT	NOTE: Tungsten carbide grit-edged blades are recommended for the saws (available from Chatfield Division).
	• SABRE SAW	• 7/16" WRENCH		



GEF INCORPORATED

6497 Winfield Rd
Winfield, WV 25213
(Office) 304-755-1600
(Toll Free) 800-784-0529
(Fax) 304-755-3150
www.gefinc.com