



SAF RAIL™

FIBERGLASS HANDRAIL & LADDER SYSTEMS





Fiberglass Handrail Systems



SAFRAIL™ system in a chemical plant.

SAFRAIL™ fiberglass handrails are industrial/commercial railing systems for stair rails, platform/walkway handrails and guardrails. SAFRAIL™ systems are fabricated from pultruded fiberglass components produced by Strongwell and molded thermoplastic connectors. The railing systems are particularly well-suited to corrosive environments like those found in industrial, chemical and wastewater treatment plants as well as commercial structures with urban and salt air corrosion.

SAFRAIL™ fiberglass handrail systems are:

- Corrosion resistant
- Structurally strong
- High impact resistant
- Lightweight
- Easy to field fabricate
- Low in thermal conductivity
- Low electrical conductivity

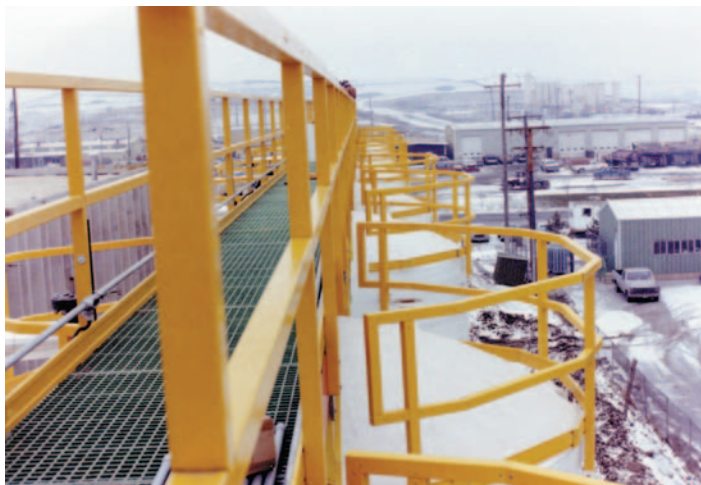

Internal connections make circular handrail systems such as these possible around tanks.

SAFRAIL™ systems are the result of more than 20 years of experience in the manufacture, design and fabrication of fiberglass handrail systems. The systems offer the following advantages:

- **Ease of Assembly** — SAFRAIL™ systems are produced in lightweight standard sections that include both post and rail. Systems can be prefabricated in large sections and shipped to the site or they can also be fabricated and installed on site with simple carpenter tools.
- **Internal Connection System** — All connections fit flush, resulting in a pleasing, streamlined appearance. The internal connections allow the construction of continuous handrail systems around circular tanks without special fittings.
- **Safety Features** — SAFRAIL™ systems come in a “safety yellow color”, feature low electrical conductivity for worker safety and exhibit high strength. Systems meet federal OSHA standards with a 2:1 factor of safety with a 6-foot maximum post spacing. SAFRAIL™ systems also comply with international standard AFNOR NF E 85-101.
- **Low Maintenance** — Corrosion resistant fiberglass with molded-in color will outlast aluminum or steel systems with virtually no maintenance.
- **Cost Effective** — Fiberglass components and easy-to-assemble design provide savings on labor and maintenance, resulting in long-term savings and elimination of the cost and inconvenience of “downtime for repairs” in plant operations.



SAFRAIL™ handrail is used on walkways and platforms for safe maintenance-free worker access.

Guardrail

SAFRAIL™ systems can be used in guardrail applications where railing is needed to protect the open side of an elevated walkway. SAFRAIL™ systems meet OSHA requirements for a height of 42” from the top of walkway to the top of the guardrail.

The OSHA loading requirement for both guardrail and handrail is a 200 pound concentrated load at any point or direction on the top rail. Other building codes may require different loading conditions.



Materials of Construction

SAFRAIL™ is an engineered composite consisting of:

- Continuous glass fibers
- Two continuous strand glass mats
- A synthetic surfacing veil
- Fire-retardant polyester resin

This unique combination provides the ultimate in strength, stiffness and long-term corrosion and UV protection.

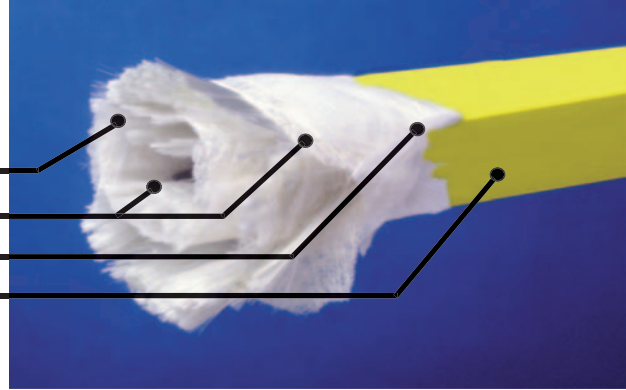

Square Post or Rail Section Properties

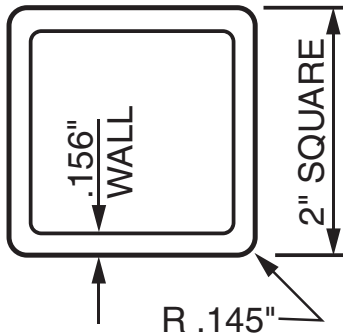

$$A = 1.151 \text{ in.}^2$$

$$S = .657 \text{ in.}^3$$

$$I = .657 \text{ in.}^4$$

$$E = 3.7 \times 10^6 \text{ psi}$$

$$WT = .95 \text{ lbs./lin.ft.}$$

where E = Flexural modulus full strength

Minimum Mechanical Properties for Pultruded Parts

Properties	Test Method	Values
Tensile Stress	ASTM D638	30,000 psi
Tensile Modulus	ASTM D638	2.5×10^6 psi
Compressive Stress	ASTM D695	30,000 psi
Compressive Modulus	ASTM D695	2.5×10^6 psi
Flexural Stress	ASTM D790	30,000 psi
Flexural Modulus	ASTM D790	1.6×10^6 psi
Shear Stress	ASTM D2344	4,500 psi
Density	ASTM D792	.060-.070 lbs./in ³
24 Hr. Water Absorption	ASTM D570	0.6% max
Coef. Thermal Expansion	ASTM D696	4.4×10^{-6} in/in/°F (min.)
Flexural Stress	Full Section	36,000 psi (typical)
Flexural Modulus	Full Section	3.7×10^6 psi (typical)



Typical Square Handrail Construction

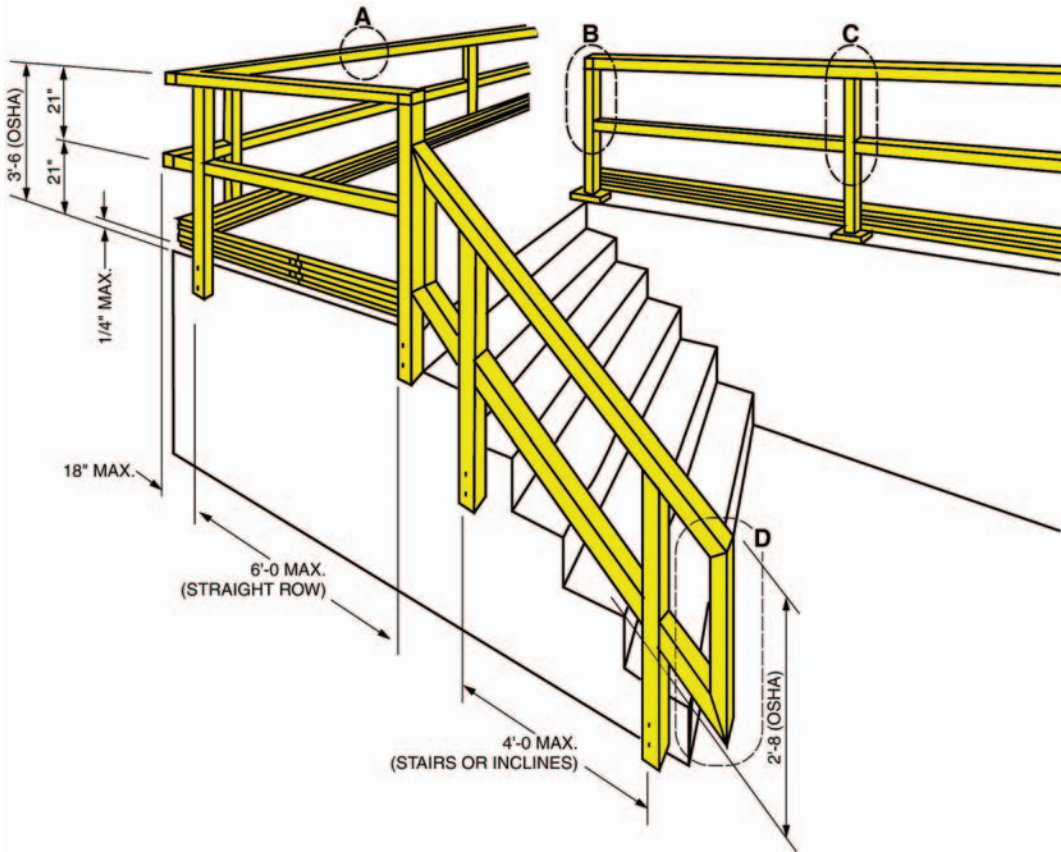

Connection Details

All components secured with epoxy.

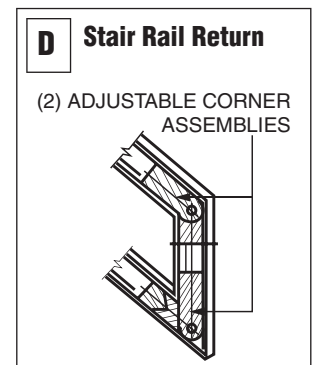
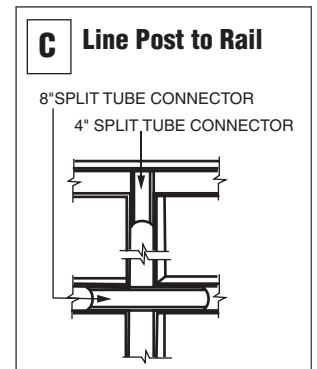
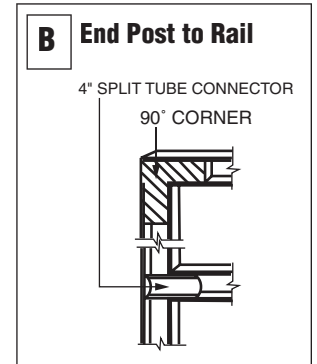
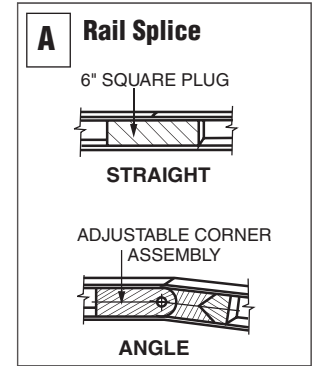

Alternative Post Design

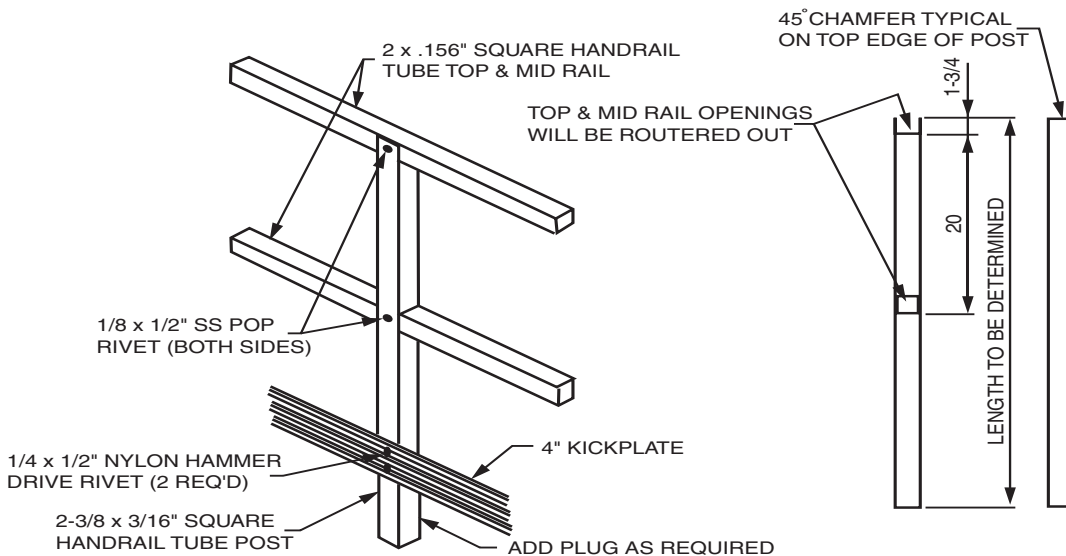



Suggested Square Post and Kick Plate Installation

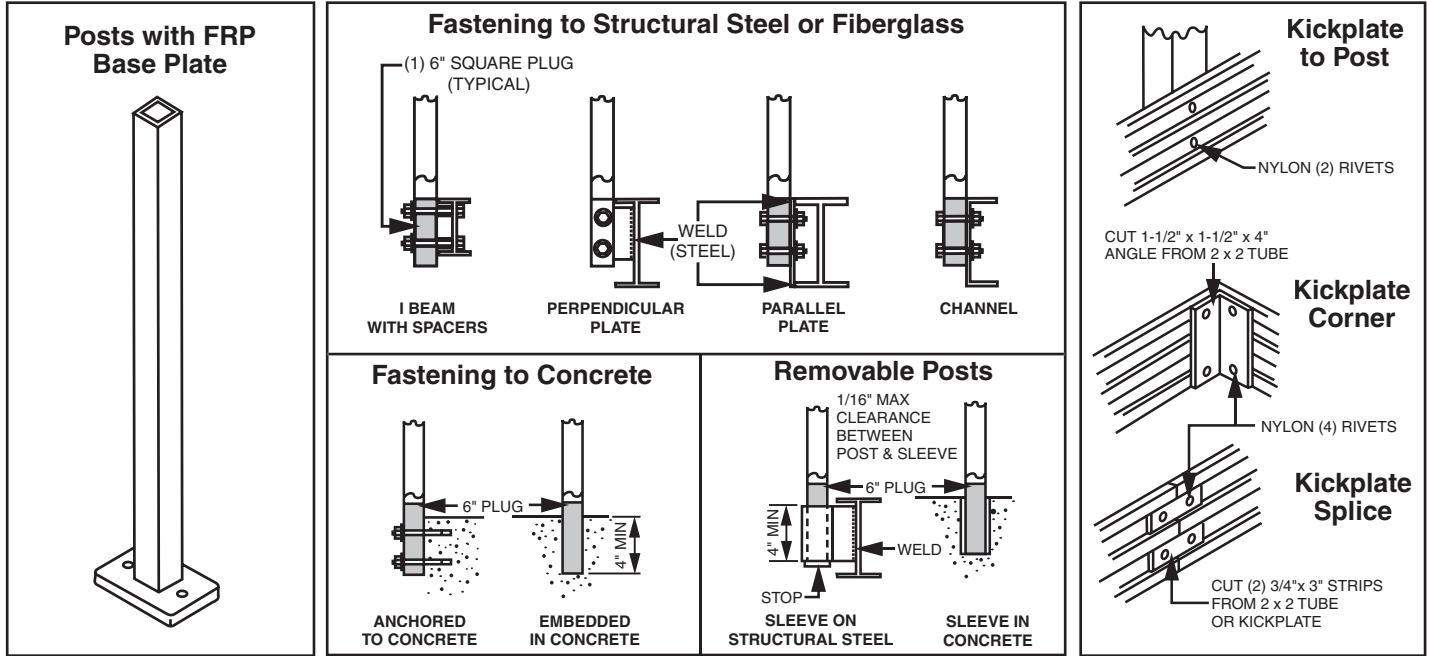

Square Handrail Components

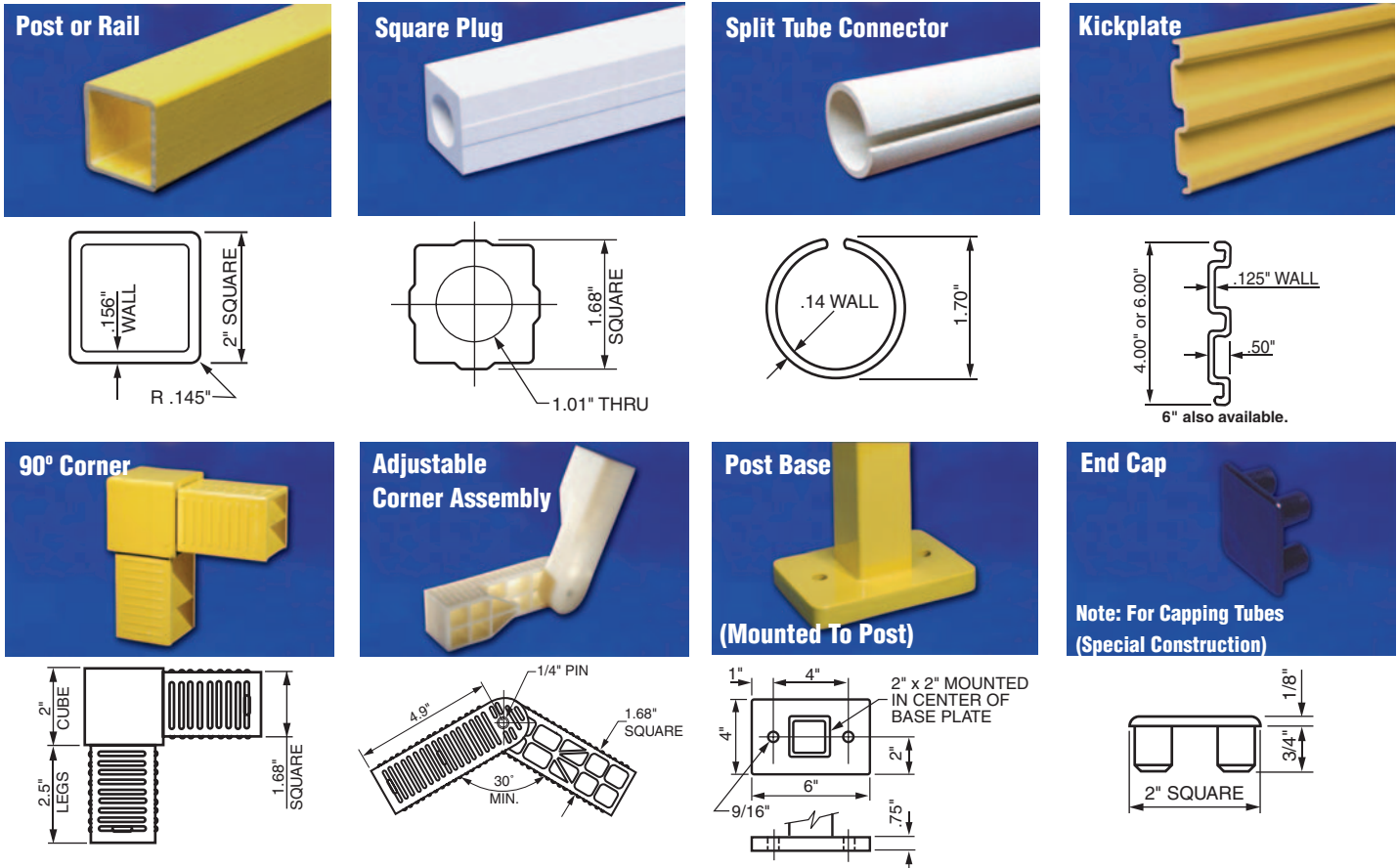



Round Handrail System

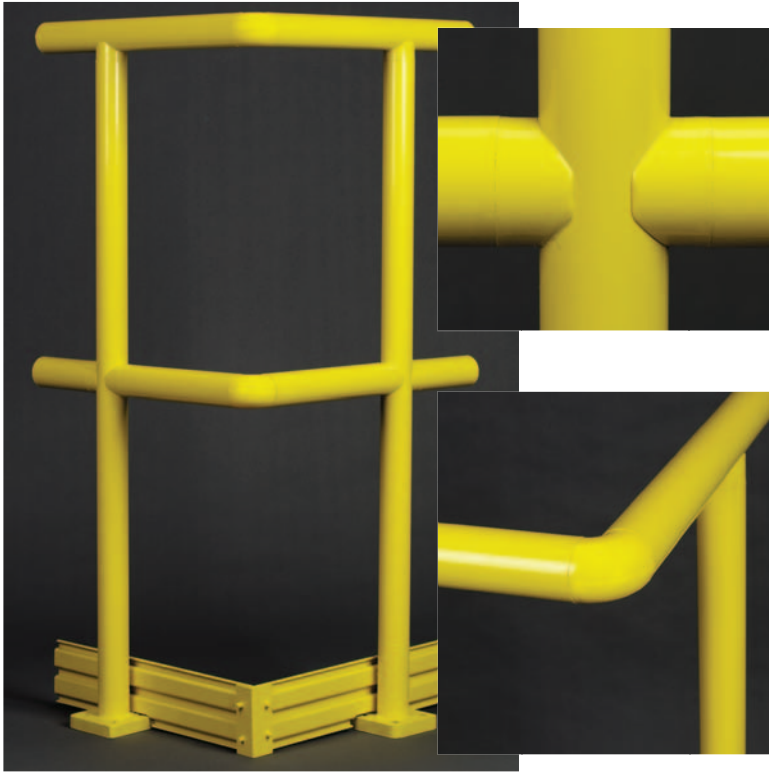

The SAFRAIL™ round handrail system is a round fiberglass system that is ideal for any high traffic area where handrail is needed. The round rails are easy to grip and 90° molded corners eliminate sharp edges.

The handrail system meets OSHA strength requirements with a 2:1 factor of safety with a 5-foot maximum post spacing. The handrail system can be made to comply with ADA standards upon request.

Internally bonded fiberglass connectors result in no visible rivets or metal parts. Rail and posts are 1.90" O.D. x 1.51" I.D. This is the same outside dimension as typical metal rails for ease of adapting to common metal brackets. Kickplates are available upon request.

The SAFRAIL™ round handrail system is pultruded using either a vinyl ester or a polyester resin system. The handrail system includes a UV inhibitor for additional resistance to ultraviolet degradation and corrosion.

Typical applications include:

- Food Processing Facilities
- Platforms & Walkways
- Heavy Industrial Plants

Post or Rail Section Properties

$$A = 1.05 \text{ in.}^2$$

$$S = .405 \text{ in.}^3$$

$$I = .385 \text{ in.}^4$$

$$E = 4.5 \times 10^6 \text{ psi}$$

$$WT = .86 \text{ lbs./lin. ft.}$$

where E = Flexural modulus full section

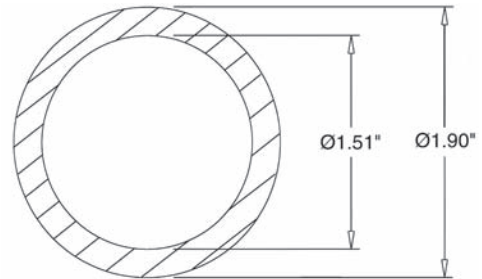

Minimum Mechanical Properties for Pultruded Rail and Post:

Properties	Test Method	Values
Tensile Stress	ASTM D638	30,000 psi
Tensile Modulus	ASTM D638	2.5×10^6 psi
Compressive Stress	ASTM D695	30,000 psi
Compressive Modulus	ASTM D695	2.5×10^6 psi
Flexural Stress	ASTM D790	30,000 psi
Flexural Modulus	ASTM D790	1.6×10^6 psi
Shear Stress	ASTM D2344	4,500 psi
Density	ASTM D792	.060-.070 lbs./in. ³
24 Hr. Water Absorption	ASTM D570	0.6% max
Coefficient of Thermal Expansion	ASTM D696	4.4×10^{-6} in./in./°F (min.)
Flexural Stress	Full Section	60,000 psi (typical)
Flexural Modulus	Full Section	4.5×10^6 psi (typical)



Typical Round Handrail Construction

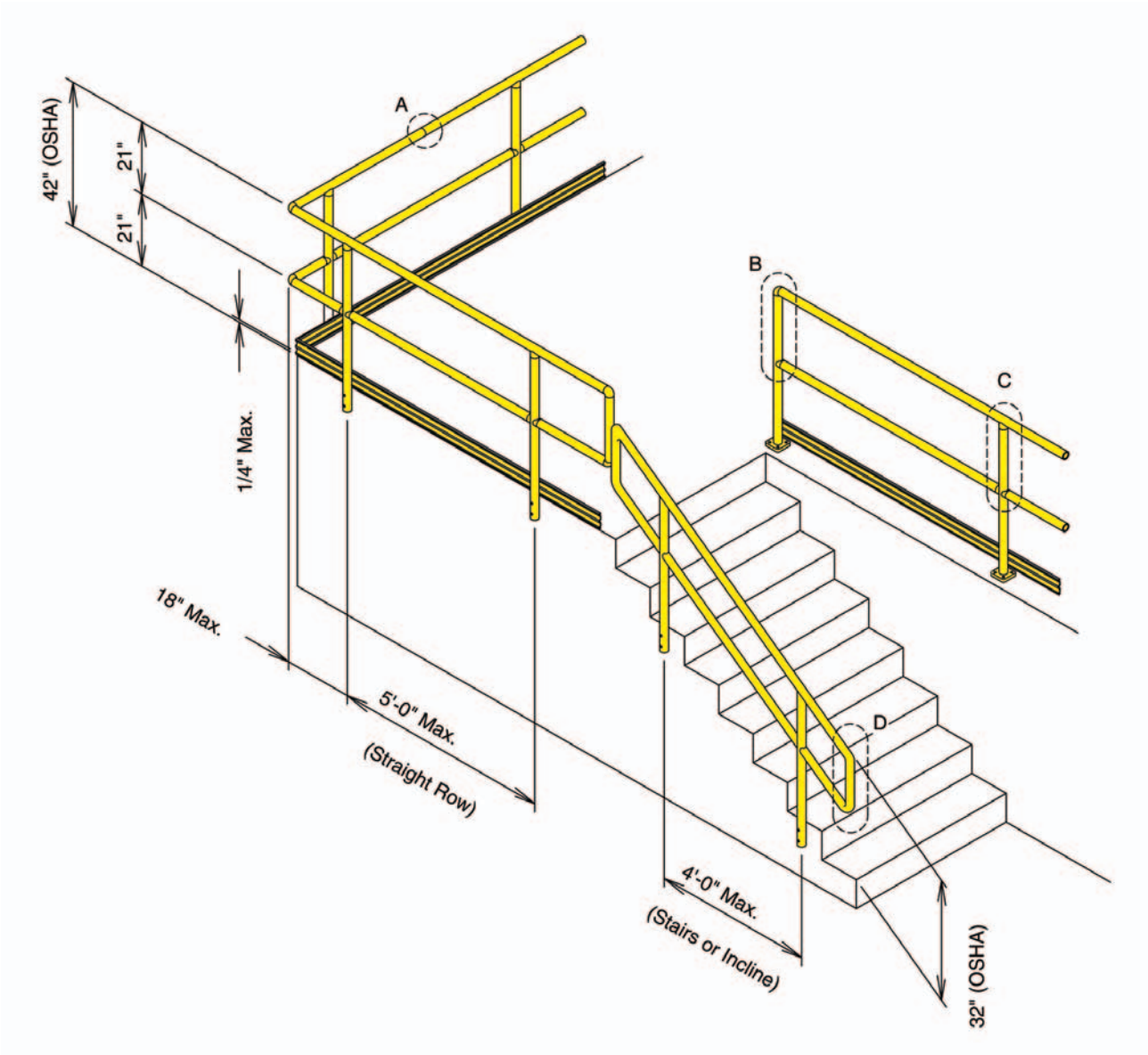

Connection Details

All components secured with epoxy.

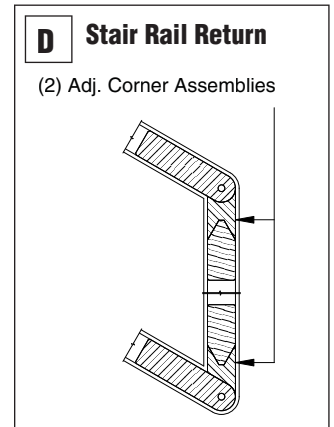
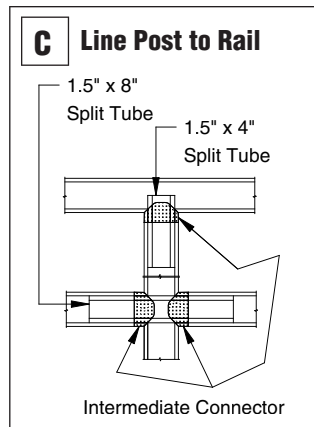
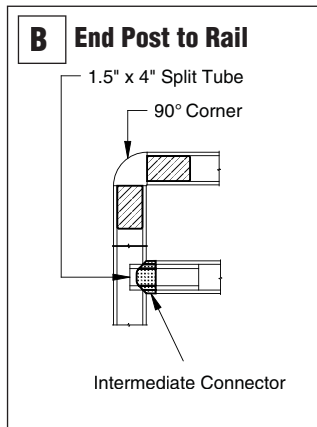
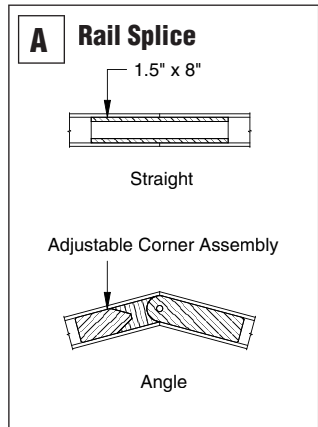

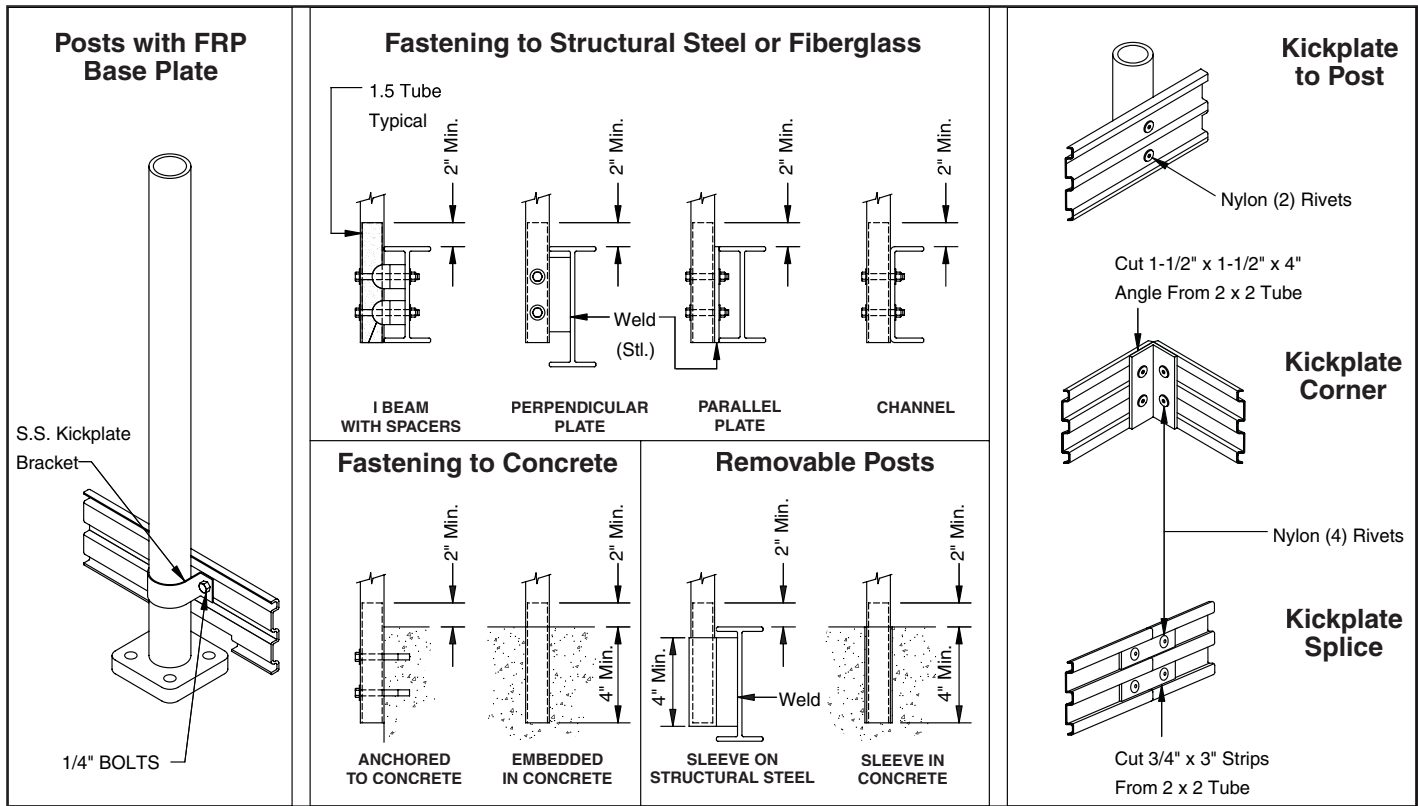

Round Handrail Components

<p>Post or Rail</p>	<p>Round Plug</p>	<p>Split Tube Connector</p>	<p>Kickplate</p>
<p>90° Corner</p>	<p>Adjustable Corner Assembly</p>	<p>Post Base (Mounted To Post)</p>	<p>End Cap</p> <p>Note: For Capping Tubes (Special)</p>



Handrail System Options

Custom Handrail Systems

SAFRAIL™ systems are designed to fit a wide variety of applications and, because they are standard systems, to be cost effective. However, custom handrail systems are available from Strongwell to suit special needs. Some examples of custom handrail from Strongwell include vertical pickets, two-color handrail, architectural handrail, heavy duty handrail and phenolic handrail systems.

UV Coating

Strongwell recommends that an industrial grade polyurethane coating be applied to the finished handrail and/or ladder and cage for additional protection in outdoor applications. Standard SAFRIL™ handrail systems are unpainted; the polyurethane UV coating must be requested when ordered.

Resin Systems

A polyester resin system is standard for SAFRIL™ handrail systems but other resin systems are available upon request.

Colors

SAFRIL™ handrail and ladder systems are produced in a standard safety yellow color. Other colors are available upon request.



This custom half round top rail is used by Fairfield Inn hotels to reduce maintenance and provide long lasting good looks.



Strongwell designed this vertical rail system to use less material and, in turn, be more cost effective than conventional horizontal aluminum or fiberglass handrail systems.



A heavy duty handrail system that uses 2" x 1/4" EXTREN® square tube built to ASTM F-1092-87 specifications is available for applications requiring added stiffness for less deflection under normal loading.



Fiberglass Ladders & Cages

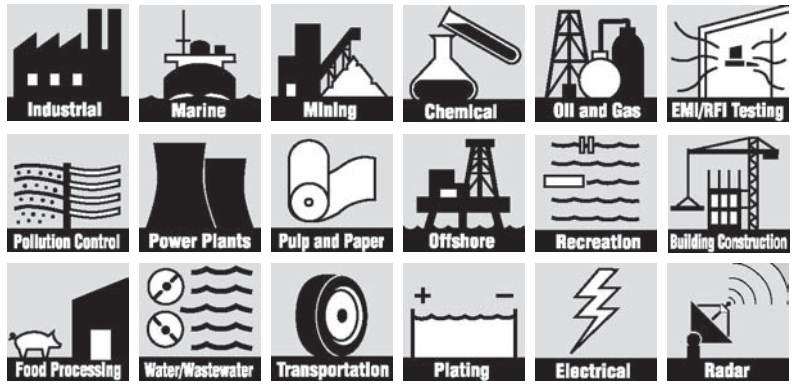

SAFRAIL™ fiberglass ladders and ladder cages mounted on the sides of tanks are a common sight in a wide range of industries. Fiberglass ladder and ladder cage systems have been in continuous use for more than 20 years in chemical plants and other corrosive environments. Even in complete immersion applications, fiberglass has outlasted aluminum and steel and required little or no maintenance.

Sizes & Availability

SAFRAIL™ ladders are fabricated in a standard 18" rung width configuration with 12" rung spacings. Various ladder lengths can be produced as practical. Standard SAFRAIL™ ladder and ladder cage systems are designed and fabricated to meet the requirements of OSHA 1910.27. Custom designed ladders and access cages can be fabricated upon request. Ladders can be shipped pre-assembled for installation in the field.

Materials of Construction

SAFRAIL™ ladders and ladder cage systems are produced in a premium grade polyester resin system with flame retardant and ultraviolet (UV) inhibitor additives. Standard side rails and cages are pigmented safety yellow. The rungs are a pultruded fiberglass polyester tube with a fluted non-skid surface.



This fiberglass ladder and ladder cage provide worker access to a maintenance platform at a Ciba Geigy plant in the northeastern United States.



Fiberglass access ladders are used throughout the service areas of Sea World, Orlando, FL to resist saltwater corrosion and reduce maintenance



High strength, maintenance free SAFRAIL™ fiberglass ladders and ladder cages are ideal for highly corrosive environments.



Ladder Systems

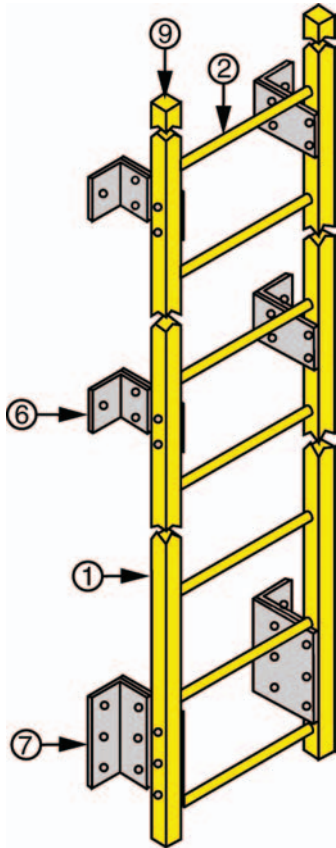

Part Identification

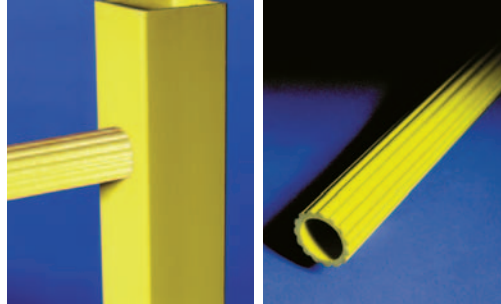

NAME	DESCRIPTION
1 Side Rail	2" x .156" sq. tube
2 Rung	1.25" dia. fluted tube
3 Top or Bottom Hoop	3" x 1/4" strip
4 Intermediate Hoop	2" x 1/4" strip
5 Cage Straps	2" x 3/16" strip
6 Standoff Bracket	5" bracket plate
7 Standoff Bracket	10-1/2" bracket plate
8 Base Angle	3" angle
9 End Plug	Molded end cap

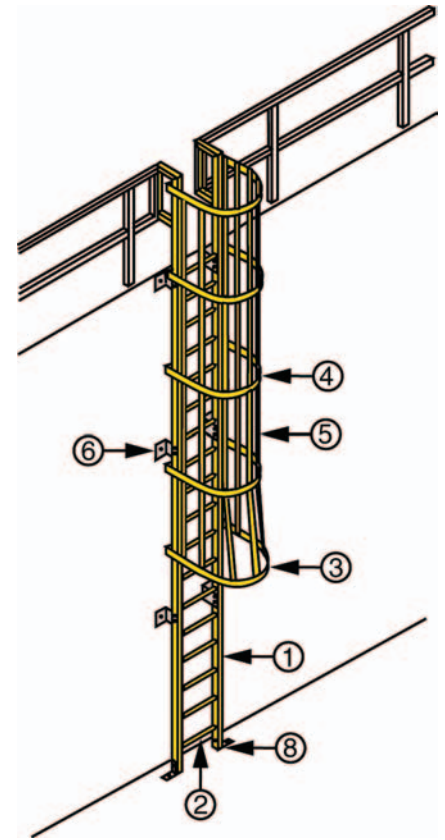

Ladder Options



Walk-Through Cage w/Return



Side Mount Cage



Walk-Through w/Return



Floor Mount



Wall Mount



Specifications

SAFRAIL™ fiberglass handrail and ladder systems shall be fabricated from pultruded fiberglass components as produced by Strongwell. Cage hoops shall be produced by the open molded hand lay-up method.

The pultruded parts shall be made with a fire retardant polyester resin which meets the ASTM E-84 test for flame spread of 25 or less and contains a UV inhibitor. The color shall be OSHA safety yellow.

SAFRAIL™ Square Handrail

The handrail system shall be designed to meet the configuration and loading requirements of OSHA 1910.23, with a minimum factor of safety on loading of 2.0.

Materials

The rails and posts shall be 2" x 2" x .156" square tube manufactured by the pultrusion process. The kickplate shall be 4" x 1/2" (corrugated) x .125" thick pultruded fiberglass shape.

Installation and Mounting

Post shall be constructed with a square pultruded bottom plug. Length shall be sufficient to extend a minimum of 1" beyond the uppermost bolt hole to prevent crushing of post tubing. Bolt holes shall provide clearance of 1/16" for 1/2" diameter bolts/studs. Holes shall be on longitudinal center line of post, 1" from bottom of post (minimum) and not less than 3" apart on center. Posts shall be fastened with stainless steel anchor bolts or studs, 1/2" diameter, extending no less than 2-1/4" into the concrete, or into a minimum thickness of 1/4" structural steel or pultruded fiberglass.

Post locations shall be no greater than 18", nor less than 9" from horizontal or vertical change in handrail direction. Post centers shall be no greater than 72" apart on any straight run of rail, or 48" apart on any inclined rail section.

Base mount, embedded, and removable are also types of mounting procedures for handrail.

The fabricated handrail systems shall be supplied complete with fittings by the FRP manufacturer. The components used to join fabricated sections together may be shipped loose, to be epoxied and riveted together in the field by the contractor, per the manufacturer's recommendations.

SAFRAIL™ Round Handrail

The handrail shall be designed to meet the configuration and loading requirement of OSHA 1910.23 with a minimum factor of safety loading of 2.0.

Materials

The rails and posts shall be 1.90" OD x 1.51" ID round tube manufactured by the pultrusion process. The kickplate shall be 4" x 1/2" (corrugated) x .125" thick pultruded fiberglass shape.

Installation and Mounting

The post shall be constructed with a round pultruded bottom plug. Length shall be sufficient to extend a minimum of 2" beyond the uppermost support structure. Bolt holes shall provide clearance of 1/16" for 1/2" diameter bolts/studs. Holes shall be on longitudinal center line of post, 1" from bottom of post (minimum) and not less than 3" apart on center. The post shall be fastened with stainless steel anchor bolts or studs, 1/2" diameter, extending no less than 2-1/2" into the concrete, or into a minimum thickness of 1/4" structural steel or pultruded fiberglass.

Post locations shall be no greater than 18", nor less than 9" from horizontal or vertical change in handrail direction. Post centers shall be no greater than 60" apart on any straight run of rail, or 48" apart on any inclined rail section.

Base mount, embedded and removable are also types of mounting procedures for handrail.

The fabricated handrail systems shall be supplied complete with fittings by the FRP manufacturer. The components used to join fabricated sections together shall be shipped loose, to be epoxied and riveted together in the field by the contractor, per the manufacturer's recommendations.

SAFRAIL™ Ladders and Ladder Cages

SAFRAIL™ fiberglass reinforced plastic (FRP) ladder and cage systems shall meet the requirements set forth in OSHA 1910.27.

Ladders shall be shop assembled and may be pre-drilled and prepared for field attachments of standoff clips.

Materials

The side rails, rungs and cage straps shall be pultruded fiberglass reinforced components. The side rails shall be 2" square tube with a wall thickness of .156" or greater. The rungs shall be pultruded 1.25" diameter FRP fluted tube.

Cage hoops shall be manufactured by the open mold hand lay-up process with a width of 3" and thickness of 1/4" minimum at the top and bottom and 2" x 1/4" at the intermediate hoops. The cage shall be interconnected with 2" x 3/16" pultruded straps spaced 9" on center around the hoop.



GEF INCORPORATED

6497 Winfield Rd
Winfield, WV 25213
(Office) 304-755-1600
(Toll Free) 800-784-0529
(Fax) 304-755-3150

www.gefinc.com